



《风光欣》技术资料

2SB772

PNP EPITAXIAL SILICON TRANSISTOR

AUDIO FREQUENCY POWER AMPLIFIER

LOW SPEED SWITCHING

*Complement to 2SD882

ABSOLUTE MAXIMUM RATINGS(TA=25)

Characteristic	Symbol	Rating	Unit
Collector-Base Voltage	V _{CB0}	-40	V
Collector-Emitter Voltage	V _{CEO}	-30	V
Emitter -Base Voltage	V _{EB0}	-5	V
Collector Current (DC)	I _c	-3	A
Collector Dissipation (Ta=25	P _c	2	W
Junction Temperature	T _J	150	
Storage Temperature	T _{STG}	-55 ~150	

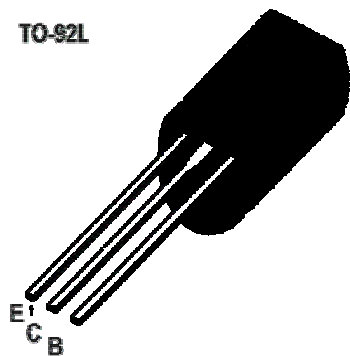

ELECTRICAL CHARACTERISTICS(TA=25)

Characteristic	Symbol	Test Conditions	Min	Typ	Max	Unit
Collector-Cut-off Current	I _{CB0}	V _{CB} = -30V, I _E =0			-1	μ A
Emitter-Cut-off Current	I _{EB0}	V _{EB} = -3V, I _c =0			-1	μ A
*DC Current Gain	h _{FE1}	V _{CE} = -2V, I _c = -20mA	30	150		
	h _{FE2}	V _{CE} = -2V, I _c = -1A	60	160	400	
*Collector-Emitter Saturation Voltage	V _{CE(sat)}	I _c = -2A, I _B = -0.2A		-0.3	-0.5	V
Base-Emitter Saturation Voltage	V _{BE(sat)}	I _c = -2A, I _B = -0.2A		-1.0	-2.0	V
Current Gain-Bandwidth Product	f _T	V _{CE} = -5V, I _E = -0.1A		90		MHZ
Output Capacitance	C _{OB}	V _{CB} = -10V, I _E =0, f=1MHZ		45		pF

*Pulse Test :PW<350US, Duty Cycle<2%

hFE (2) CLASSIFICATION

Classification	R	Q	P	I
HFE(2)	60-120	160-200	160-320	200-400